

Strength Building Gear

823101

LEG HOLD DOWN

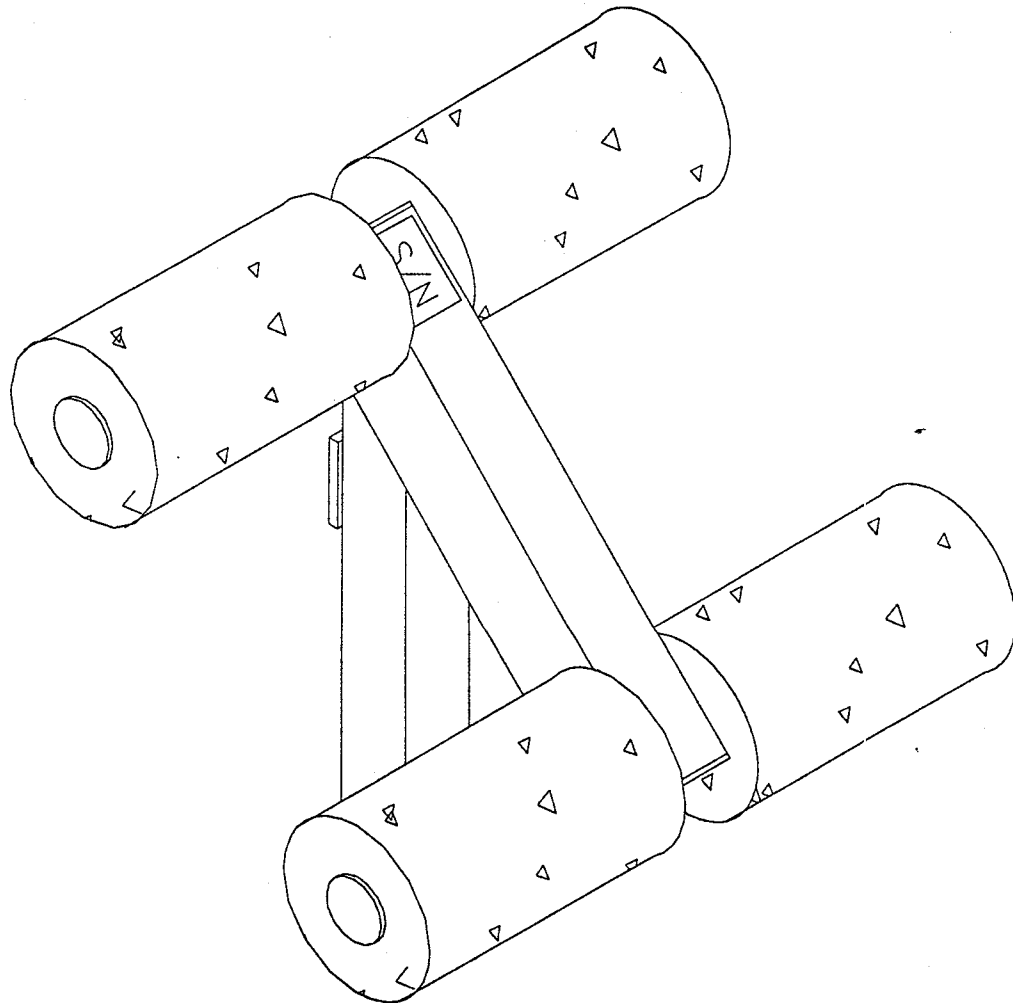

**PRODUCT ASSEMBLY
INSTRUCTIONS SHEETS**

823101 LEG HOLD DOWN ASSEMBLY PARTS LIST

SORT AND COUNT ALL PARTS BEFORE BEGINNING ASSEMBLY

HARDWARE:

ITEM	NAME/DESCRIPTION	QTY
1.	3/4 IN. STARLOCK COLLAR	4
2.	1-3/4 IN. SQ. END CAP	2

WELDMENTS/PARTS:

ITEM	NAME/DESCRIPTION	QTY
1.	LEG HOLD DOWN FRAME WLDMT(6416001)	1
2.	ROLLER PAD SHAFT(6125101)	2
3.	ROLLER PAD(6194601)	4

NOTE: BOLT LENGTH IS MEASURED FROM THE UNDERSIDE OF THE HEAD OF THE BOLT.

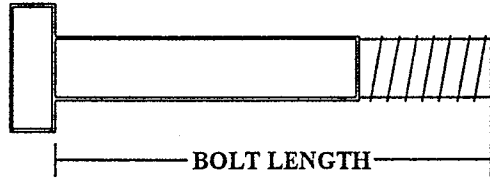

BOLT LENGTH RULER:

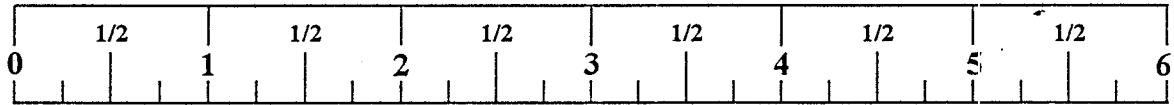

823101 LEG HOLD DOWN ASSEMBLY INSTRUCTIONS

THANK YOU

FOR PURCHASING THE 823101 LEG HOLD DOWN. PLEASE SAVE THESE ASSEMBLY INSTRUCTIONS FOR YOUR PERSONAL REFERENCE, AND ADDITIONAL SERVICE INFORMATION.

IMPORTANT

- IF YOU EXPERIENCE ANY PROBLEM WITH THE ASSEMBLY OF THIS PRODUCT, PLEASE CONTACT YOUR DEALER OR YOUR PARABODY CUSTOMER SERVICE REPRESENTATIVE AT: 1-800-328-9714
- **TOOLS REQUIRED:** RUBBER Mallet or HAMMER

1. Insert two (2) 1-3/4 IN. SQ. END CAP into both ends of the **LEG HOLD DOWN FRAME** as shown on drawing.
2. Assemble four (4) **ROLLER PADS** to the **LEG HOLD DOWN FRAME** as shown on drawing, using two (2) **ROLLER PAD SHAFTS**, and four (4) 3/4 IN. **STARLOCK COLLARS**.
3. To perform **DECLINES** or **AB CRUNCHES**, insert the **LEG HOLD DOWN ASSEMBLY** into the **UPRIGHT TUBE** of the **BENCH FRAME** as shown on drawing, and tighten in place using the **THUMBSCREW**. To adjust the **SEAT PAD** for the **DECLINE** position, pull out on the **U-PIN**. Rotate the **U-PIN** back pass the **FIRST PIN STOP**. Release the **U-PIN**, and allow it to rest up against the **SECOND PIN STOP**.

REVISIONS	
NO.	DESCRIPTION
A	ISSUE
B	ISSUE
C	ISSUE
D	ISSUE
E	ISSUE

NOT AS SHOWN

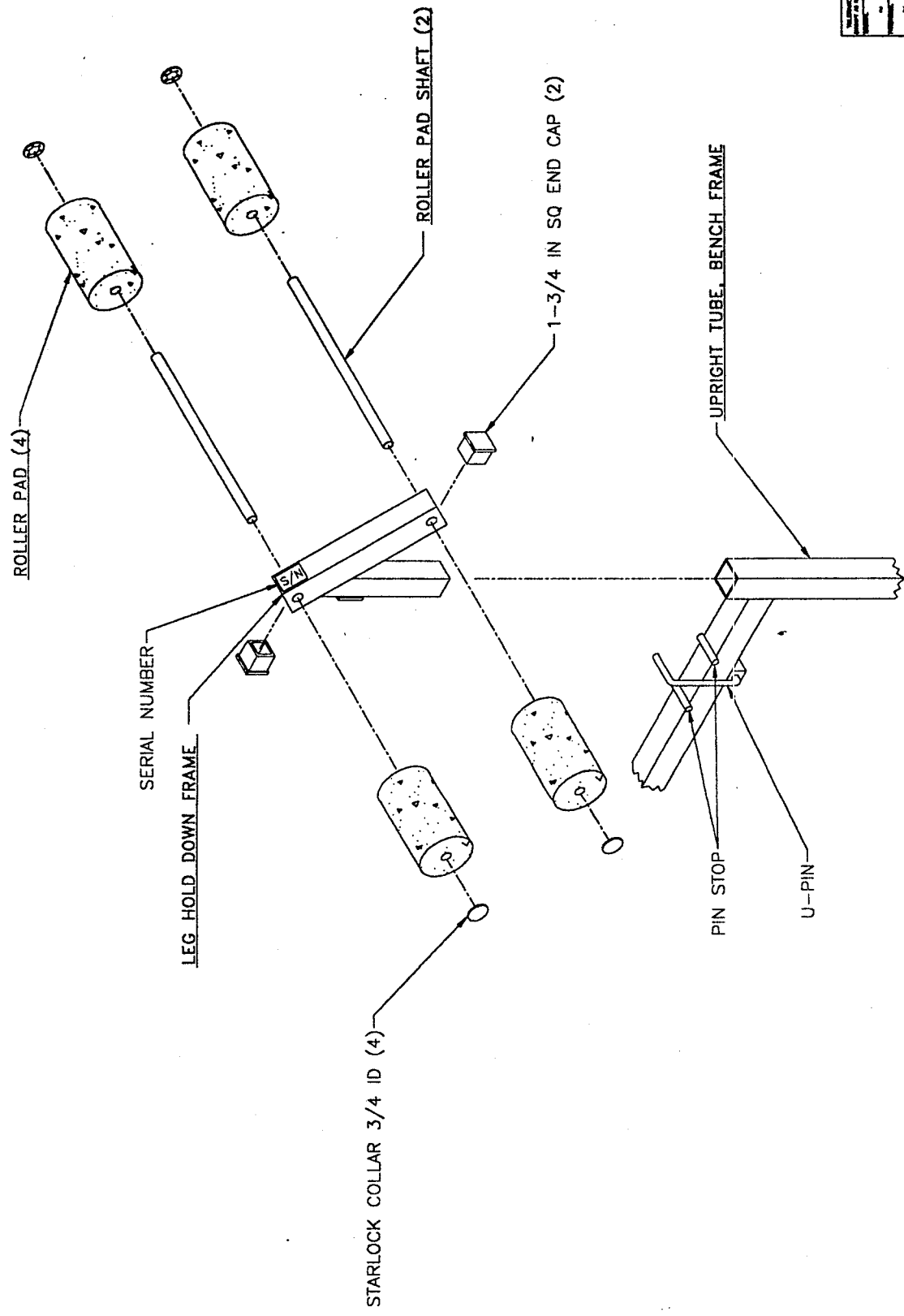

PARABODY INC. MADISON, WISCONSIN	
ASST. INST. 823101	64172
1/2	0
1/2	0
1/2	0
1/2	0